

Programmable DC-Balanced 21-Bit Serializers

General Description

The MAX9209/MAX9213 serialize 21 bits of LVTTTL/LVCMOS parallel input data to three LVDS outputs. A parallel rate clock on a fourth LVDS output provides timing for deserialization.

The MAX9209/MAX9213 feature programmable DC balance, which allows isolation between the serializer and deserializer using AC-coupling. The DC balance circuits on each channel code the data, limiting the imbalance of transmitted ones and zeros to a defined range. The companion MAX9210/MAX9214 deserializers decode the data. When DC balance is not programmed, the serializers are compatible with non-DC-balanced, 21-bit serializers such as the DS90CR215 and DS90CR217.

Two frequency ranges and two DC-balance default conditions are available for maximum replacement flexibility and compatibility with existing non-DC-balanced serializers.

The MAX9209/MAX9213 are available in TSSOP and space-saving thin QFN packages.

Applications

Automotive Navigation Systems
Automotive DVD Entertainment Systems
Digital Copiers
Laser Printers

Functional Diagram

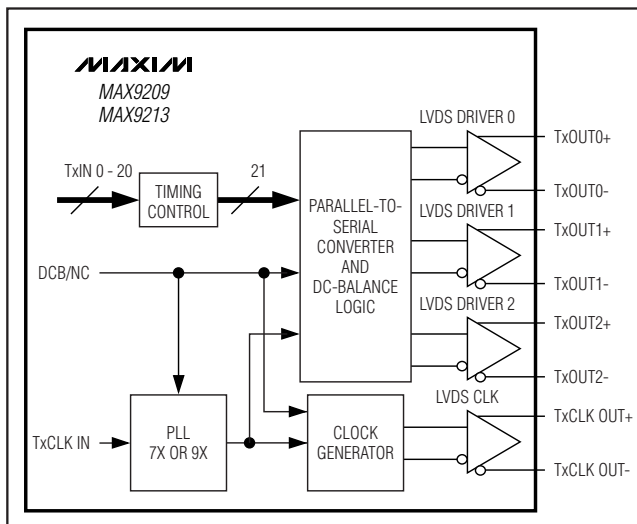

Pin Configurations appear at end of data sheet.

Features

- ◆ Programmable DC-Balanced or Non-DC-Balanced Operation
- ◆ DC Balance Allows AC-Coupling for Ground-Shift Tolerance
- ◆ As Low as 8MHz Operation
- ◆ Pin Compatible with DS90CR215 and DS90CR217 in Non-DC-Balanced Mode
- ◆ Integrated 110Ω (DC-Balanced) and 410Ω (Non-DC-Balanced) Output Resistors
- ◆ 5V Tolerant LVTTTL/LVCMOS Data Inputs
- ◆ PLL Requires No External Components
- ◆ Up to 1.785Gbps Throughput
- ◆ LVDS Outputs Meet IEC 61000-4-2 and ISO 10605 Requirements
- ◆ LVDS Outputs Conform to ANSI TIA/EIA-644 LVDS Standard
- ◆ Low-Profile 48-Lead TSSOP and Space-Saving QFN Packages
- ◆ -40°C to +85°C Operating Temperature Range
- ◆ +3.3V Supply

Ordering Information

| PART | TEMP RANGE | PIN-PACKAGE |
|-------------|-----------------|------------------|
| MAX9209ETM* | -40°C to +85°C | 48 Thin QFN-EP** |
| MAX9209EUM | -40°C to +85°C | 48 TSSOP |
| MAX9209GUM | -40°C to +105°C | 48 TSSOP |
| MAX9213ETM | -40°C to +85°C | 48 Thin QFN-EP** |
| MAX9213EUM | -40°C to +85°C | 48 TSSOP |

*Future product—contact factory for availability.

**EP = Exposed pad.

Programmable DC-Balanced 21-Bit Serializers

ABSOLUTE MAXIMUM RATINGS

V_{CC} to GND-0.5V to +4.0V
 LVDS Outputs (TxOUT₋, TxCLK OUT₋) to GND-0.5V to +4.0V
 5V Tolerant LVTTTL/LVC MOS Inputs
 (TxIN₋, TxCLK IN, PWRDWN) to GND-0.5V to +6.0V
 (DCB/NC) to GND-0.5V to (V_{CC} + 0.5V)
 LVDS Outputs (TxOUT₋, TxCLK OUT₋)
 Short to GND and Differential ShortContinuous
 Continuous Power Dissipation (T_A = +70°C)
 48-Pin TSSOP (derate 16mW/°C above +70°C) 1282mW
 48-Lead QFN (derate 26.3mW/°C above +70°C)2105mW
 Storage Temperature Range-65°C to +150°C

Junction Temperature+150°C
 ESD Protection
 Human Body Model (R_D = 1.5kΩ, C_S = 100pF)
 All Pins to GND±2kV
 IEC 61000-4-2 (R_D = 330Ω, C_S = 150pF)
 Contact Discharge (TxOUT₋, TxCLK OUT₋) to GND±8kV
 Air Gap Discharge (TxOUT₋, TxCLK OUT₋) to GND ..±15kV
 ISO 10605 (R_D = 2kΩ, C_S = 330pF)
 Contact Discharge (TxOUT₋, TxCLK OUT₋) to GND±8kV
 Air Gap Discharge (TxOUT₋, TxCLK OUT₋) to GND ..±25kV
 Lead Temperature (soldering, 10s)+300°C

Stresses beyond those listed under "Absolute Maximum Ratings" may cause permanent damage to the device. These are stress ratings only, and functional operation of the device at these or any other conditions beyond those indicated in the operational sections of the specifications is not implied. Exposure to absolute maximum rating conditions for extended periods may affect device reliability.

DC ELECTRICAL CHARACTERISTICS

(V_{CC} = +3.0V to +3.6V, R_L = 100Ω ±1%, PWRDWN = high, DCB/NC = high or low, unless otherwise noted. Typical values are at V_{CC} = +3.3V, T_A = +25°C.) (Notes 1, 2)

| PARAMETER | SYMBOL | CONDITIONS | MIN | TYP | MAX | UNITS | |
|---|------------------|---|-----------------|------|-----------------------|-------|---|
| SINGLE-ENDED INPUTS (TxIN₋, TxCLK IN, PWRDWN, DCB/NC) | | | | | | | |
| High-Level Input Voltage | V _{IH} | TxIN ₋ , TxCLK IN, PWRDWN | 2.0 | | 5.5 | V | |
| | | DCB/NC | 2.0 | | V _{CC} + 0.3 | | |
| Low-Level Input Voltage | V _{IL} | | -0.3 | | +0.8 | V | |
| Input Current | I _{IN} | V _{IN} = high or low, PWRDWN = high or low | -20 | | +20 | μA | |
| Input Clamp Voltage | V _{CL} | I _{CL} = -18mA | | -0.9 | -1.5 | V | |
| LVDS OUTPUTS (TxOUT₋, TxCLK OUT) | | | | | | | |
| Differential Output Voltage | V _{OD} | Figure 1 | 250 | 350 | 450 | mV | |
| Change in V _{OD} Between Complementary Output States | ΔV _{OD} | Figure 1 | | 2 | 25 | mV | |
| Output Offset Voltage | V _{OS} | Figure 1 | 1.125 | 1.25 | 1.375 | V | |
| Change in V _{OS} Between Complementary Output States | ΔV _{OS} | Figure 1 | | 10 | 30 | mV | |
| Output Short-Circuit Current | I _{OS} | V _{OUT+} or V _{OUT-} = 0V or V _{CC} , non-DC-balanced mode | -10 | ±5.7 | +10 | mA | |
| | | V _{OUT+} or V _{OUT-} = 0V or V _{CC} , DC-balanced mode | -15 | ±8.2 | +15 | | |
| Magnitude of Differential Output Short-Circuit Current | I _{OSD} | V _{OD} = 0V, non-DC-balanced mode (Note 3) | | 5.7 | 10 | mA | |
| | | V _{OD} = 0V, DC-balanced mode (Note 3) | | 8.2 | 15 | | |
| Differential Output Resistance | R _O | DC-balanced mode | | 78 | 110 | 147 | Ω |
| | | | -40°C to +105°C | 78 | 110 | 150 | |
| | | Non-DC-balanced mode | | 292 | 410 | 547 | |
| | | | -40°C to +105°C | 292 | 410 | 564 | |

Programmable DC-Balanced 21-Bit Serializers

MAX9209/MAX9213

DC ELECTRICAL CHARACTERISTICS (continued)

($V_{CC} = +3.0V$ to $+3.6V$, $R_L = 100\Omega \pm 1\%$, $\overline{PWRDWN} = \text{high}$, DCB/NC = high or low, unless otherwise noted. Typical values are at $V_{CC} = +3.3V$, $T_A = +25^\circ\text{C}$.) (Notes 1, 2)

| PARAMETER | SYMBOL | CONDITIONS | MIN | TYP | MAX | UNITS |
|-------------------------------|-----------|--|---------------|-----------|------|---------------|
| Output High-Impedance Current | I_{OZ} | $\overline{PWRDWN} = \text{low}$ or $V_{CC} = 0V$, $V_{OUT+} = 0V$ or $3.6V$, $V_{OUT-} = 0V$ or $3.6V$ | -0.5 | ± 0.1 | +0.5 | μA |
| Worst-Case Supply Current | I_{CCW} | DC-balanced mode, worst-case pattern, $C_L = 5\text{pF}$, Figure 2 | 8MHz MAX9209 | 40 | 54 | mA |
| | | | 16MHz MAX9209 | 48 | 68 | |
| | | | 34MHz MAX9209 | 71 | 90 | |
| | | | 16MHz MAX9213 | 46 | 64 | |
| | | | 34MHz MAX9213 | 59 | 87 | |
| | | | 66MHz MAX9213 | 94 | 108 | |
| | | Non-DC-balanced mode, worst-case pattern, $C_L = 5\text{pF}$, Figure 2 | 10MHz MAX9209 | 30 | 39 | |
| | | | 20MHz MAX9209 | 37 | 53 | |
| | | | 33MHz MAX9209 | 49 | 70 | |
| | | | 40MHz MAX9209 | 56 | 75 | |
| | | | 20MHz MAX9213 | 36 | 49 | |
| | | | 33MHz MAX9213 | 45 | 62 | |
| | | | 40MHz MAX9213 | 49 | 70 | |
| | | | 66MHz MAX9213 | 68 | 89 | |
| 85MHz MAX9213 | 83 | 100 | | | | |
| Power-Down Supply Current | I_{CCZ} | $\overline{PWRDWN} = \text{low}$ | | 17 | 50 | μA |

Programmable DC-Balanced 21-Bit Serializers

AC ELECTRICAL CHARACTERISTICS

($V_{CC} = +3.0V$ to $+3.6V$, $R_L = 100\Omega \pm 1\%$, $C_L = 5pF$, $\overline{PWRDWN} = \text{high}$, $DCB/NC = \text{high or low}$, unless otherwise noted. Typical values are at $V_{CC} = +3.3V$, $T_A = +25^\circ C$.) (Notes 4, 5)

| PARAMETER | SYMBOL | CONDITIONS | | MIN | TYP | MAX | UNITS |
|----------------------------------|--------|---|---------------|--------------------------|-------------------|--------------------------|-------|
| LVDS Low-to-High Transition Time | LLHT | Figure 3 | MAX9209 | 150 | 280 | 400 | ps |
| | | | MAX9213 | 150 | 260 | 350 | |
| LVDS High-to-Low Transition Time | LHLT | Figure 3 | MAX9209 | 150 | 280 | 400 | ps |
| | | | MAX9213 | 150 | 260 | 350 | |
| TxCLK IN Transition Time | TCIT | Figure 4 | | | | 4 | ns |
| Output Pulse Position | TPPosN | N = 0, 1, 2, 3, 4, 5, 6 non-DC-balanced mode, Figure 5 (Note 6) | 10MHz MAX9209 | $N/7 \times TCIP - 0.25$ | $N/7 \times TCIP$ | $N/7 \times TCIP + 0.25$ | ns |
| | | | 20MHz MAX9209 | $N/7 \times TCIP - 0.15$ | $N/7 \times TCIP$ | $N/7 \times TCIP + 0.15$ | |
| | | | 40MHz MAX9209 | $N/7 \times TCIP - 0.1$ | $N/7 \times TCIP$ | $N/7 \times TCIP + 0.1$ | |
| | | | 20MHz MAX9213 | $N/7 \times TCIP - 0.25$ | $N/7 \times TCIP$ | $N/7 \times TCIP + 0.25$ | |
| | | | 40MHz MAX9213 | $N/7 \times TCIP - 0.15$ | $N/7 \times TCIP$ | $N/7 \times TCIP + 0.15$ | |
| | | | 85MHz MAX9213 | $N/7 \times TCIP - 0.1$ | $N/7 \times TCIP$ | $N/7 \times TCIP + 0.1$ | |
| | | N = 0, 1, 2, 3, 4, 5, 6, 7, 8 DC-balanced mode, Figure 6 (Note 6) | 8MHz MAX9209 | $N/9 \times TCIP - 0.25$ | $N/9 \times TCIP$ | $N/9 \times TCIP + 0.25$ | |
| | | | 16MHz MAX9209 | $N/9 \times TCIP - 0.15$ | $N/9 \times TCIP$ | $N/9 \times TCIP + 0.15$ | |
| | | | 34MHz MAX9209 | $N/9 \times TCIP - 0.1$ | $N/9 \times TCIP$ | $N/9 \times TCIP + 0.1$ | |
| | | | 16MHz MAX9213 | $N/9 \times TCIP - 0.25$ | $N/9 \times TCIP$ | $N/9 \times TCIP + 0.25$ | |
| | | | 34MHz MAX9213 | $N/9 \times TCIP - 0.15$ | $N/9 \times TCIP$ | $N/9 \times TCIP + 0.15$ | |
| | | | 66MHz MAX9213 | $N/9 \times TCIP - 0.1$ | $N/9 \times TCIP$ | $N/9 \times TCIP + 0.1$ | |

Programmable DC-Balanced 21-Bit Serializers

MAX9209/MAX9213

AC ELECTRICAL CHARACTERISTICS (continued)

($V_{CC} = +3.0V$ to $+3.6V$, $R_L = 100\Omega \pm 1\%$, $C_L = 5pF$, $\overline{PWRDWN} = \text{high}$, $DCB/NC = \text{high or low}$, unless otherwise noted. Typical values are at $V_{CC} = +3.3V$, $T_A = +25^\circ C$.) (Notes 4, 5)

| PARAMETER | SYMBOL | CONDITIONS | MIN | TYP | MAX | UNITS |
|--|----------|---------------------------------------|------------|-----|--------------|-------|
| TxCLK IN High Time | TCIH | Figure 7 | 0.3 x TCIP | | 0.7 x TCIP | ns |
| TxCLK IN Low Time | TCIL | Figure 7 | 0.3 x TCIP | | 0.7 x TCIP | ns |
| TxIN to TxCLK IN Setup | TSTC | Figure 7 | 2.2 | | | ns |
| TxIN to TxCLK IN Hold | THTC | Figure 7 | 0 | | | ns |
| TxCLK IN to TxCLK OUT Delay | TCCD | Non-DC-balanced mode, Figure 8 | 3.5 | 4.5 | 6.0 | ns |
| | | DC-balanced mode, Figure 8 | 4.7 | 5.9 | 7.2 | |
| Serializer Phase-Locked Loop Set | TPLLS | Figure 9 | | | 32800 x TCIP | ns |
| Serializer Power-Down Delay | TPDD | Figure 10 | | 14 | 50 | ns |
| TxCLK IN Cycle-to-Cycle Jitter (Input Clock Requirement) | TJIT | | | | 2 | ns |
| Magnitude of Differential Output Voltage | V_{OD} | 595Mbps data rate, worst-case pattern | 250 | | | mV |

Note 1: Current into a pin is defined as positive. Current out of a pin is defined as negative. All voltages are referenced to ground except V_{OD} , ΔV_{OD} , and ΔV_{OS} .

Note 2: Maximum and minimum limits over temperature are guaranteed by design and characterization. Devices are production tested at $T_A = +25^\circ C$.

Note 3: Guaranteed by design.

Note 4: TCIP is the period of TxCLK IN.

Note 5: AC parameters are guaranteed by design and characterization, and are not production tested. Limits are set at ± 6 sigma.

Note 6: Pulse position TPosN is characterized using $2^7 - 1$ PRBS data.

Typical Operating Characteristics

($V_{CC} = +3.3V$, $R_L = 100\Omega \pm 1\%$, $C_L = 5pF$, $\overline{PWRDWN} = \text{high}$, $T_A = +25^\circ C$, unless otherwise noted.)

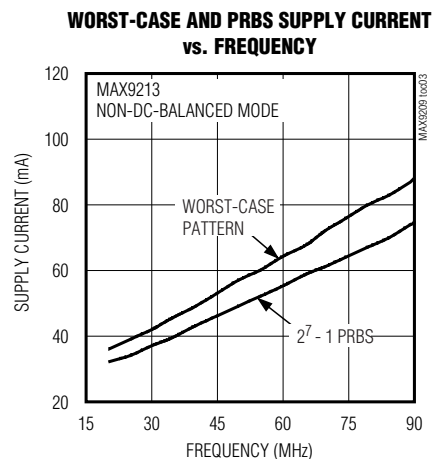
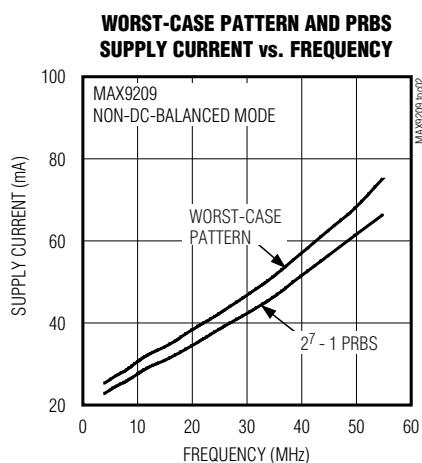
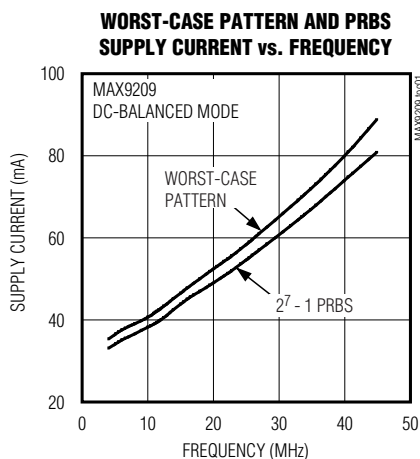

Programmable DC-Balanced 21-Bit Serializers

Typical Operating Characteristics (continued)

($V_{CC} = +3.3V$, $R_L = 100\Omega \pm 1\%$, $C_L = 5pF$, $PWRDWN = high$, $T_A = +25^\circ C$, unless otherwise noted.)

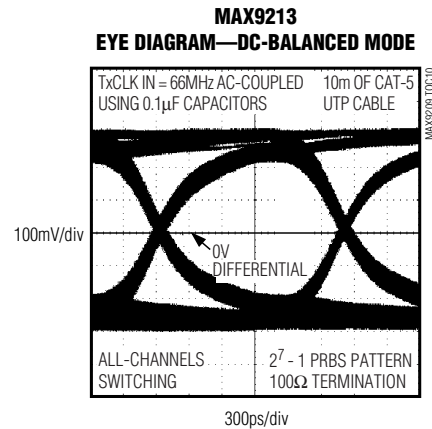
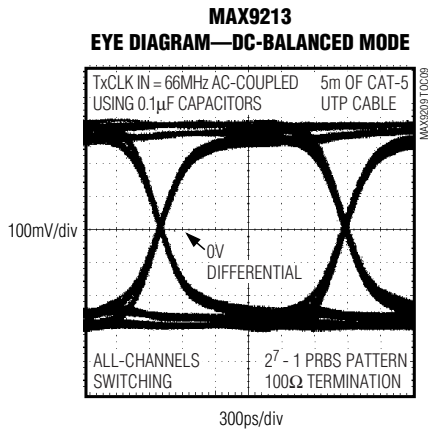
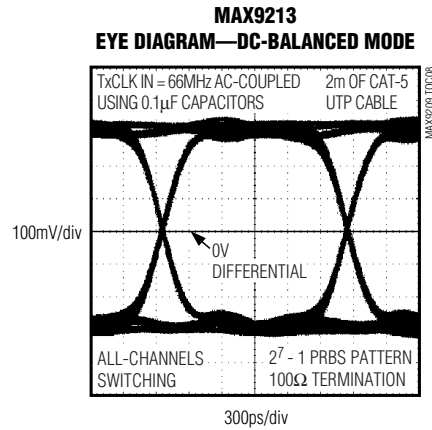
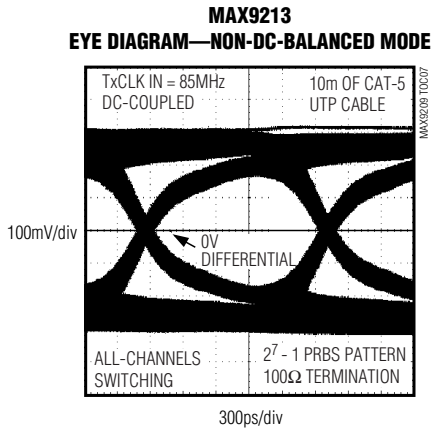
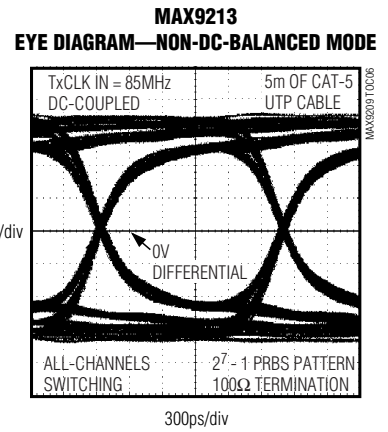
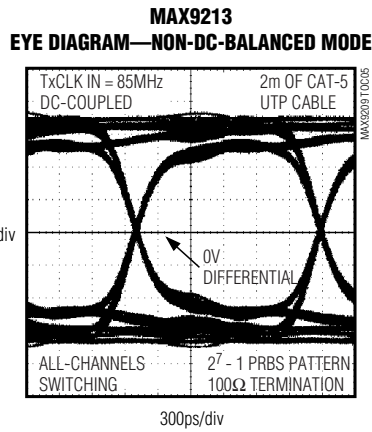
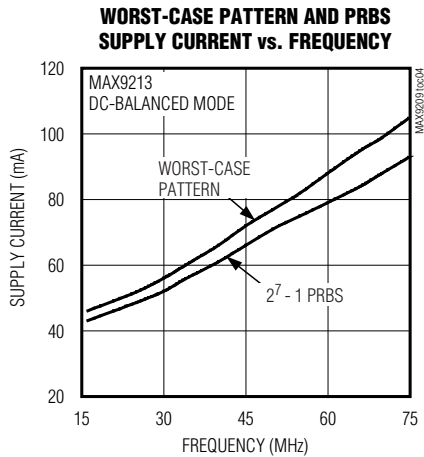

Programmable DC-Balanced 21-Bit Serializers

Pin Description

| PIN | | NAME | FUNCTION |
|----------------------------|----------------------------|----------------------------|--|
| TSSOP | QFN | | |
| 1, 3, 4, 44, 45, 47, 48, | 38, 39, 41, 42, 43, 45, 46 | TxIN0–TxIN6 | 5V Tolerant LVTTTL/LVCMOS Channel 0 Data Inputs. Internally pulled down to GND. |
| 2, 8, 14, 21 | 2, 8, 15, 44 | V _{CC} | Digital Supply Voltage |
| 5, 11, 17, 24, 46 | 5, 11, 18, 40, 47 | GND | Ground |
| 6, 7, 9, 10, 12, 13, 15 | 1, 3, 4, 6, 7, 9, 48 | TxIN7–TxIN13 | 5V Tolerant LVTTTL/LVCMOS Channel 1 Data Inputs. Internally pulled down to GND. |
| 16, 18, 19, 20, 22, 23, 25 | 10, 12, 13, 14, 16, 17, 19 | TxIN14–TxIN20 | 5V Tolerant LVTTTL/LVCMOS Channel 2 Data Inputs. Internally pulled down to GND. |
| 26 | 20 | TxCLK IN | 5V Tolerant LVTTTL/LVCMOS Parallel Rate Clock Input. Internally pulled down to GND. |
| 27 | 21 | $\overline{\text{PWRDWN}}$ | 5V Tolerant LVTTTL/LVCMOS Power-Down Input. Internally pulled down to GND. Outputs are high impedance when $\overline{\text{PWRDWN}}$ = low or open. |
| 28, 30 | 22, 24 | PLL GND | PLL Ground |
| 29 | 23 | PLL V _{CC} | PLL Supply Voltage |
| 31, 36, 42 | 25, 30, 36 | LVDS GND | LVDS Ground |
| 32 | 26 | TxCLK OUT+ | Noninverting LVDS Parallel Rate Clock Output |
| 33 | 27 | TxCLK OUT- | Inverting LVDS Parallel Rate Clock Output |
| 34 | 28 | TxOUT2+ | Noninverting Channel 2 LVDS Serial Data Output |
| 35 | 29 | TxOUT2- | Inverting Channel 2 LVDS Serial Data Output |
| 37 | 31 | LVDS V _{CC} | LVDS Supply Voltage |
| 38 | 32 | TxOUT1+ | Noninverting Channel 1 LVDS Serial Data Output |
| 39 | 33 | TxOUT1- | Inverting Channel 1 LVDS Serial Data Output |
| 40 | 34 | TxOUT0+ | Noninverting Channel 0 LVDS Serial Data Output |
| 41 | 35 | TxOUT0- | Inverting Channel 0 LVDS Serial Data Output |
| 43 | 37 | DCB/NC | LVTTTL/LVCMOS DC-Balance Programming Input: MAX9209: pulled up to V _{CC} MAX9213: pulled up to V _{CC} See Table 1. |
| — | EP | EP | Exposed Paddle. Solder to ground. |

MAX9209/MAX9213

Programmable DC-Balanced 21-Bit Serializers

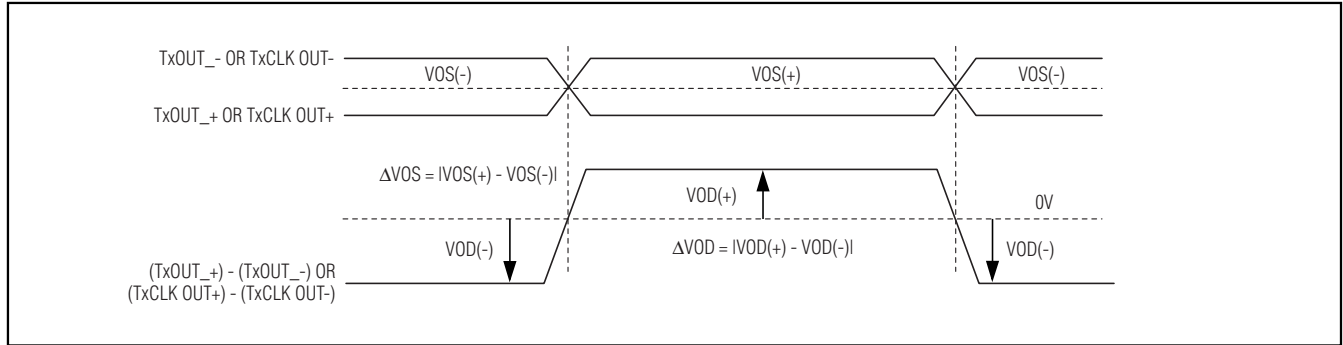

Figure 1. LVDS Output DC Parameters

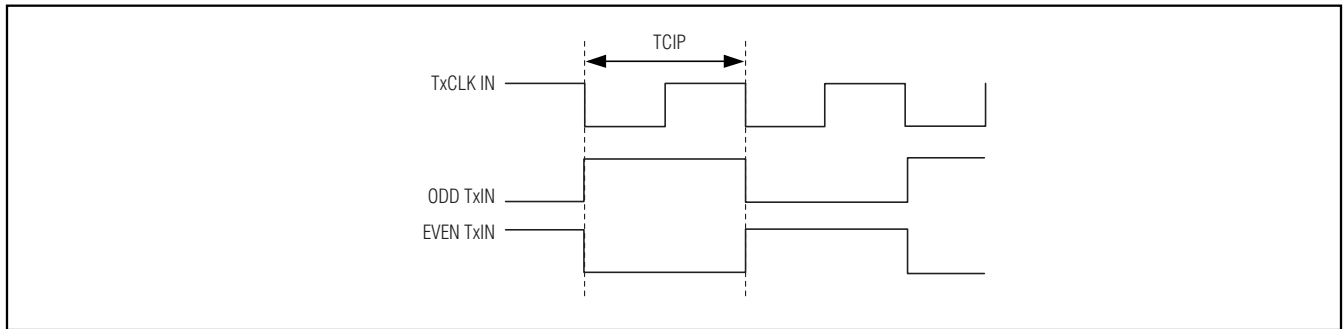

Figure 2. Worst-Case Test Pattern

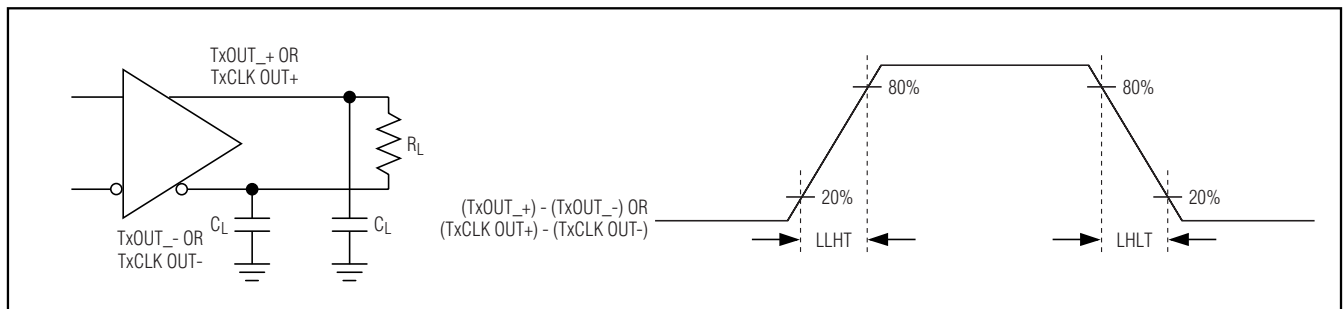

Figure 3. LVDS Output Load and Transition Times

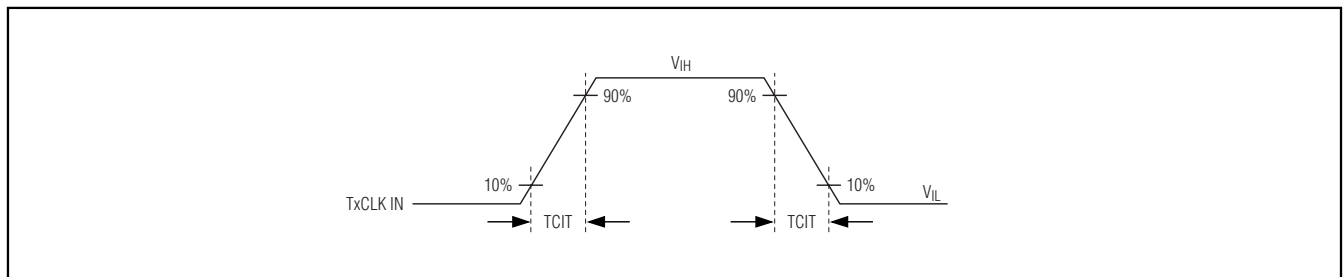

Figure 4. Clock Transition Time Waveform

Programmable DC-Balanced 21-Bit Serializers

MAX9209/MAX9213

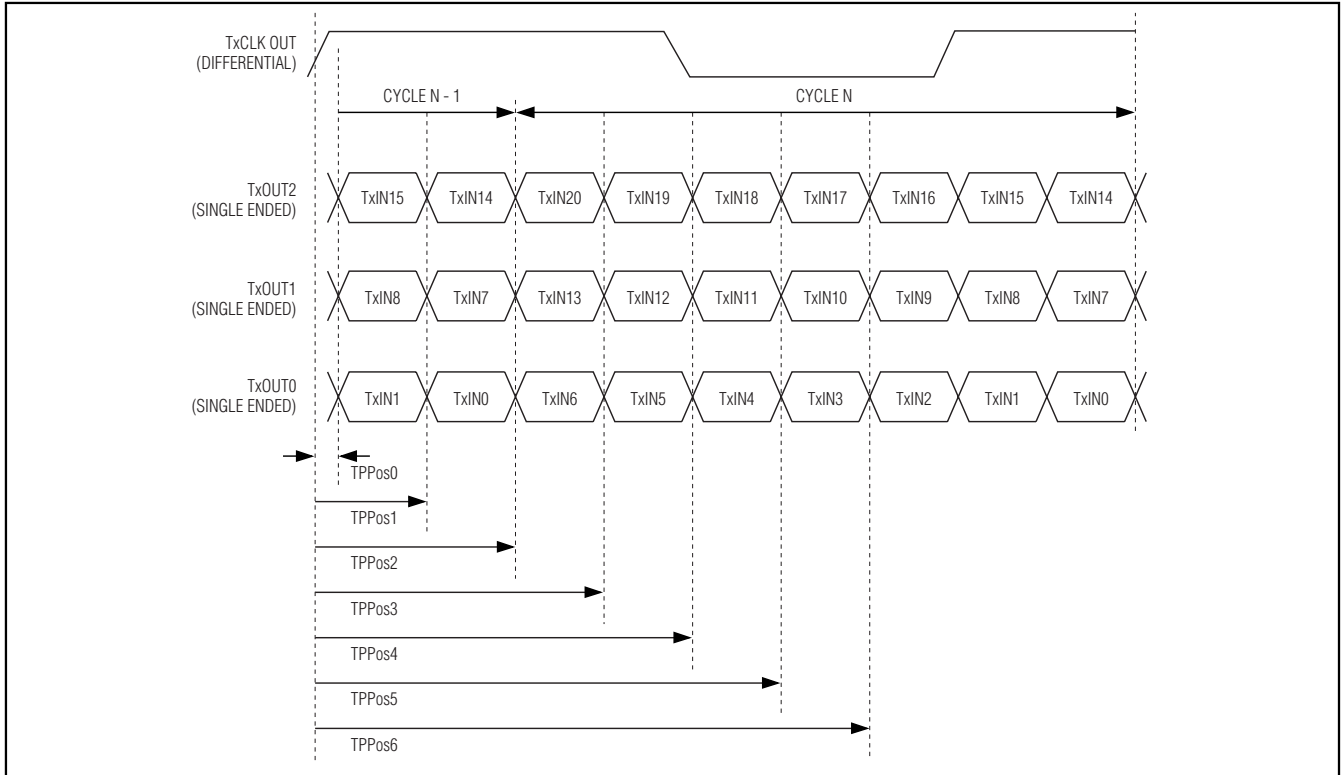

Figure 5. Non-DC-Balanced Mode LVDS Output Pulse Position Measurement

Detailed Description

The MAX9209 operates at a parallel clock frequency of 8MHz to 34MHz in DC-balanced mode and 10MHz to 40MHz in non-DC-balanced mode. The MAX9213 operates at a parallel clock frequency of 16MHz to 66MHz in DC-balanced mode and 20MHz to 85MHz in non-DC-balanced mode.

DC-balanced or non-DC-balanced operation is controlled by the DCB/NC pin (see Table 1). In non-DC-balanced mode, each channel serializes 7 bits every cycle of the parallel clock. In DC-balanced mode, 9 bits are serialized every clock cycle (7 data bits + 2 DC-balance bits). The highest data rate in DC-balanced mode for the MAX9213 is 66MHz x 9 = 594Mbps. In non-DC-balanced mode, the maximum data rate is 85MHz x 7 = 595Mbps. A bit time is 1 divided by the data rate, for example, 1 / 595Mbps = 1.68ns.

DC Balance

Through data coding, the DC-balance circuits limit the imbalance of ones and zeros transmitted on each channel. If +1 is assigned to each binary one transmitted

Table 1. DC-Balance Programming

| DEVICE | DCB/NC | OPERATING MODE | OPERATING FREQUENCY (MHz) |
|---------|--------------|-----------------|---------------------------|
| MAX9209 | High or open | DC balanced | 8 to 34 |
| | Low | Non-DC balanced | 10 to 40 |
| MAX9213 | High or open | DC balanced | 16 to 66 |
| | Low | Non-DC balanced | 20 to 85 |

and -1 is assigned to each binary zero transmitted, the variation in the running sum of assigned values is called the digital sum variation (DSV). The maximum DSV for the MAX9209/MAX9213 data channels is 10. At most, 10 more zeros than ones, or 10 more ones than zeros, are transmitted. The maximum DSV for the clock channel is 5. Limiting the DSV and choosing the correct coupling capacitors maintain differential signal amplitude and reduce jitter due to droop on AC-coupled links.

Programmable DC-Balanced 21-Bit Serializers

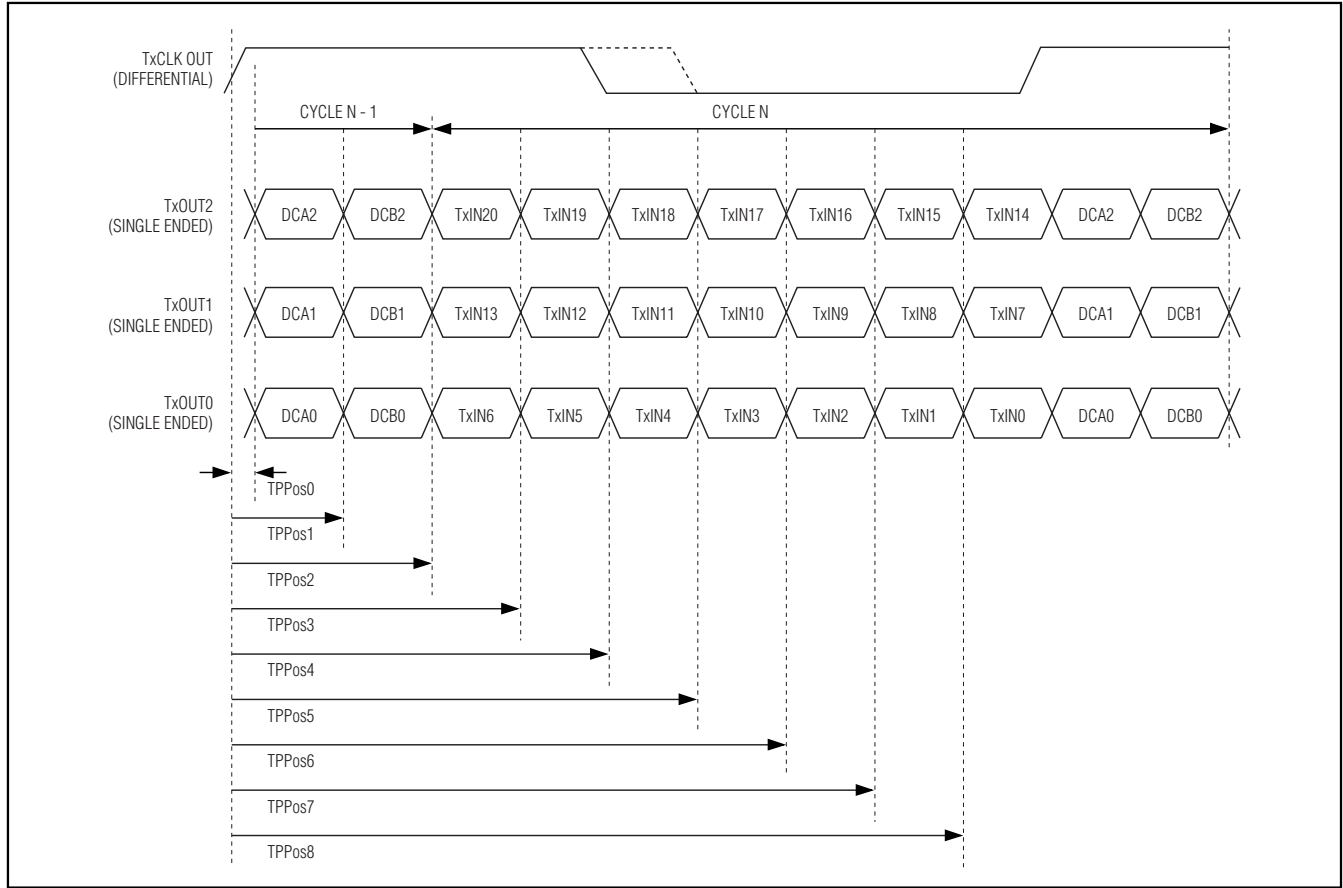

Figure 6. DC-Balanced Mode LVDS Output Pulse Position Measurement

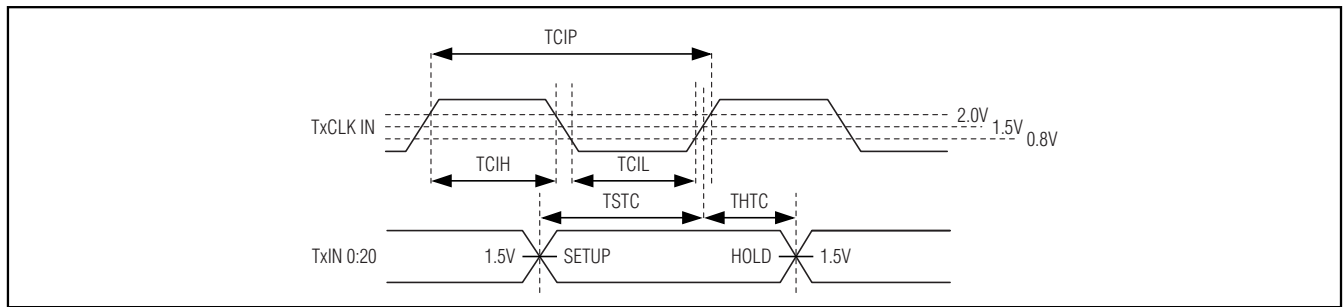

Figure 7. Setup and Hold, High and Low Times

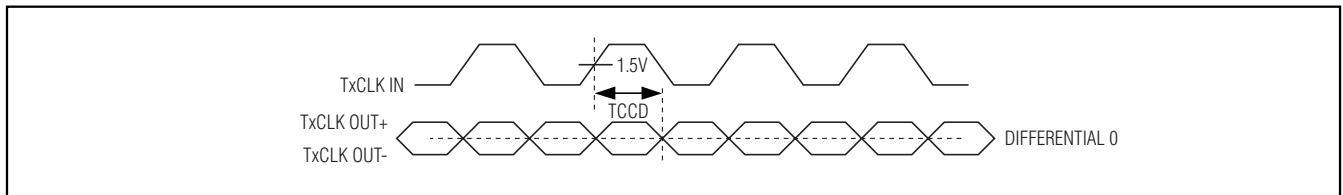

Figure 8. Clock-In to Clock-Out Delay

Programmable DC-Balanced 21-Bit Serializers

MAX9209/MAX9213

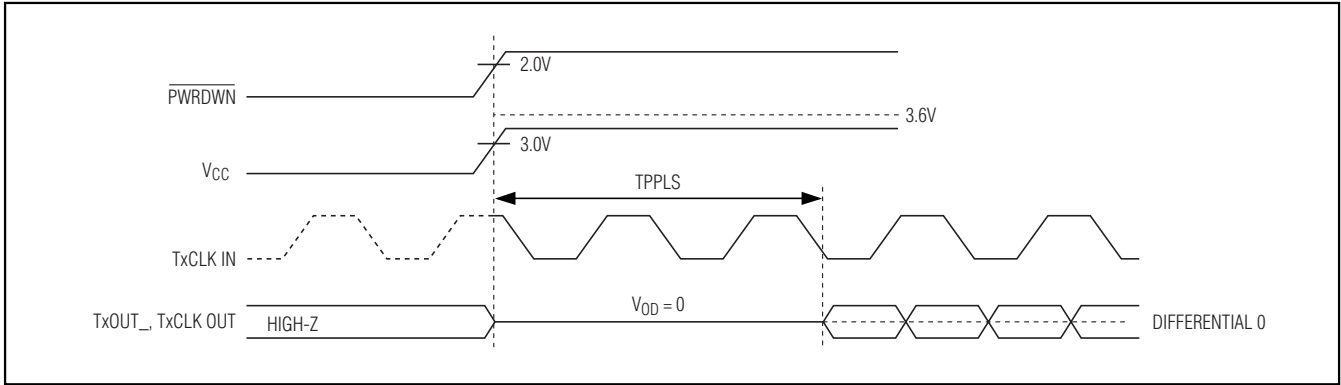

Figure 9. PLL Set Time

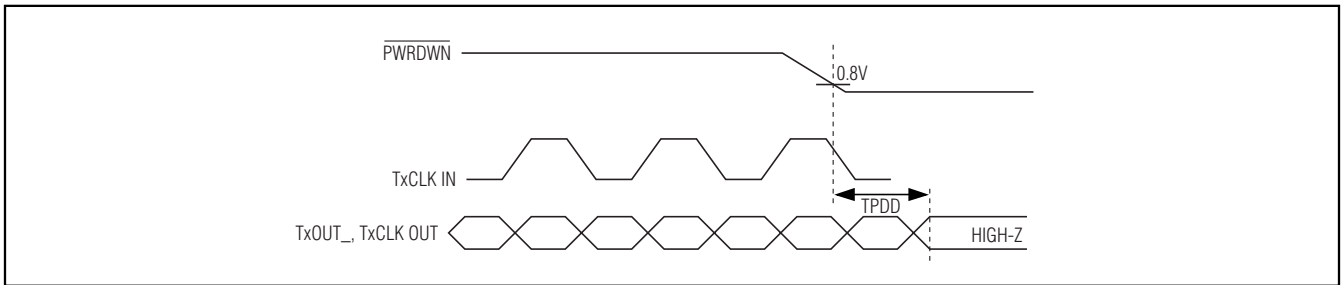

Figure 10. Power-Down Delay

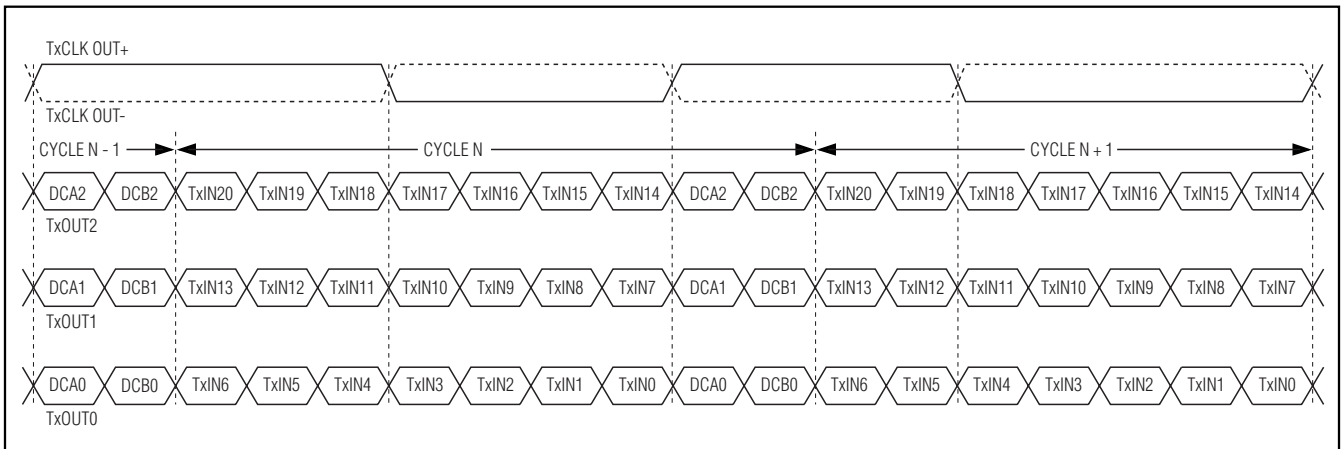

Figure 11. DC-Balanced Mode Inputs Mapped to LVDS Outputs

To obtain DC balance on the data channels, the parallel input data is inverted or not inverted, depending on the sign of the digital sum at the word boundary. Two complementary bits are appended to each group of 7 parallel input data bits to indicate to the MAX9210/MAX9214 deserializers whether the data bits are inverted (Figure 11). The deserializer restores the original

state of the parallel data. The LVDS clock signal alternates duty cycles of 4/9 and 5/9, which maintains DC balance. Figure 12 shows the non-DC-balanced mode inputs mapped to LVDS outputs.

Programmable DC-Balanced 21-Bit Serializers

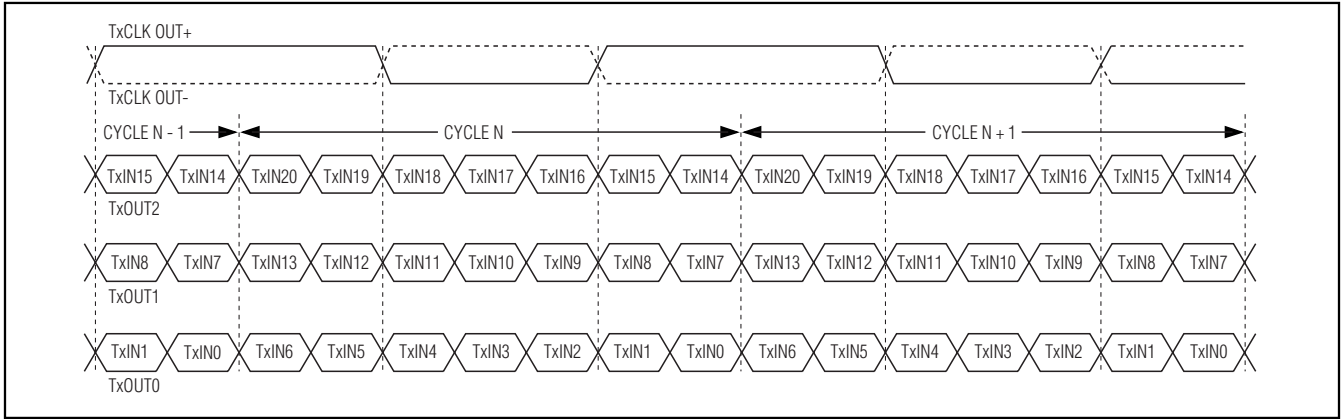

Figure 12. Non-DC-Balanced Mode Inputs Mapped to LVDS Outputs

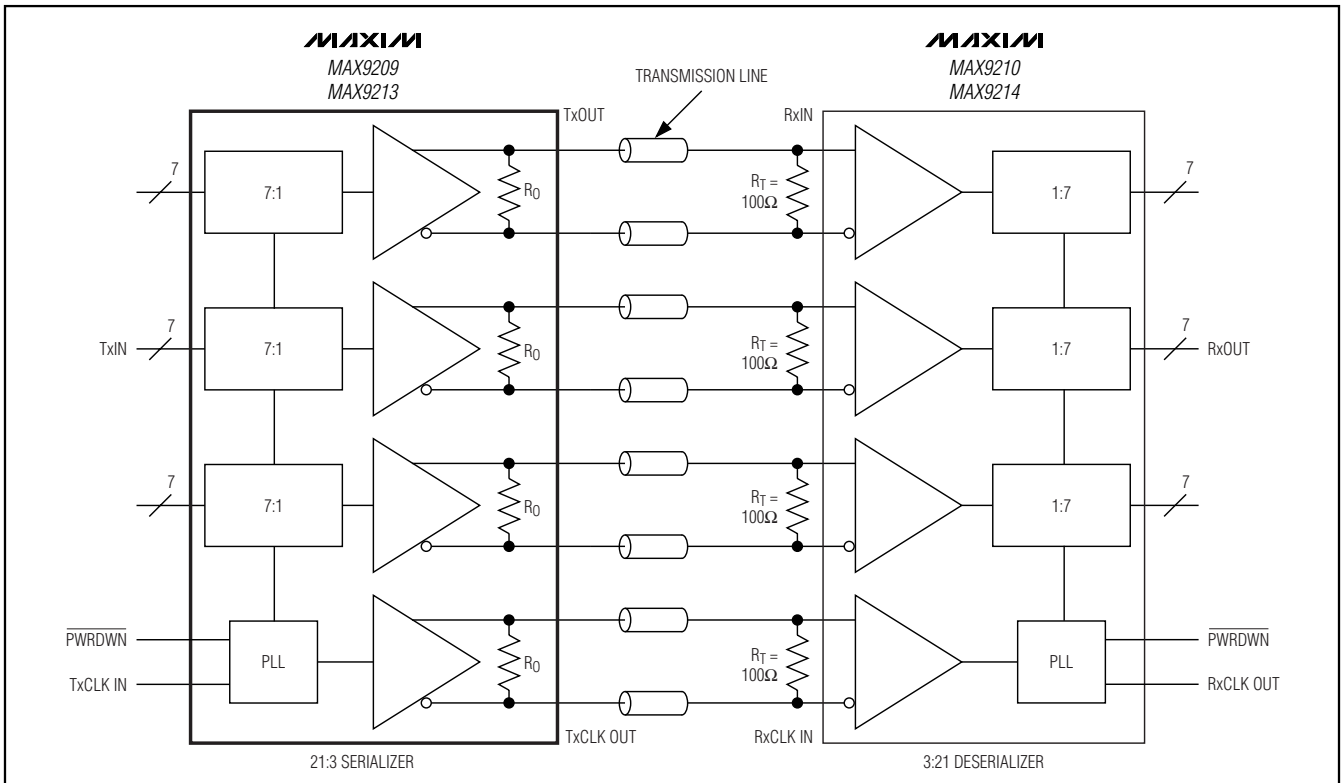

Figure 13. DC-Coupled Link, Non-DC-Balanced Mode

AC-Coupling Benefits

Bit errors experienced with DC-coupling can be eliminated by increasing the receiver common-mode voltage range by AC-coupling. AC-coupling increases the common-mode voltage range of an LVDS receiver to nearly the voltage rating of the capacitor. The typical LVDS driver output is 350mV centered on an offset volt-

age of 1.25V, making single-ended output voltages of 1.425V and 1.075V. An LVDS receiver accepts signals from 0V to 2.4V, allowing approximately ±1V common-mode difference between the driver and receiver on a DC-coupled link (2.4V - 1.425V = 0.975V and 1.075V - 0V = 1.075V). Figure 13 shows the DC-coupled link, non-DC-balanced mode.

Programmable DC-Balanced 21-Bit Serializers

MAX9209/MAX9213

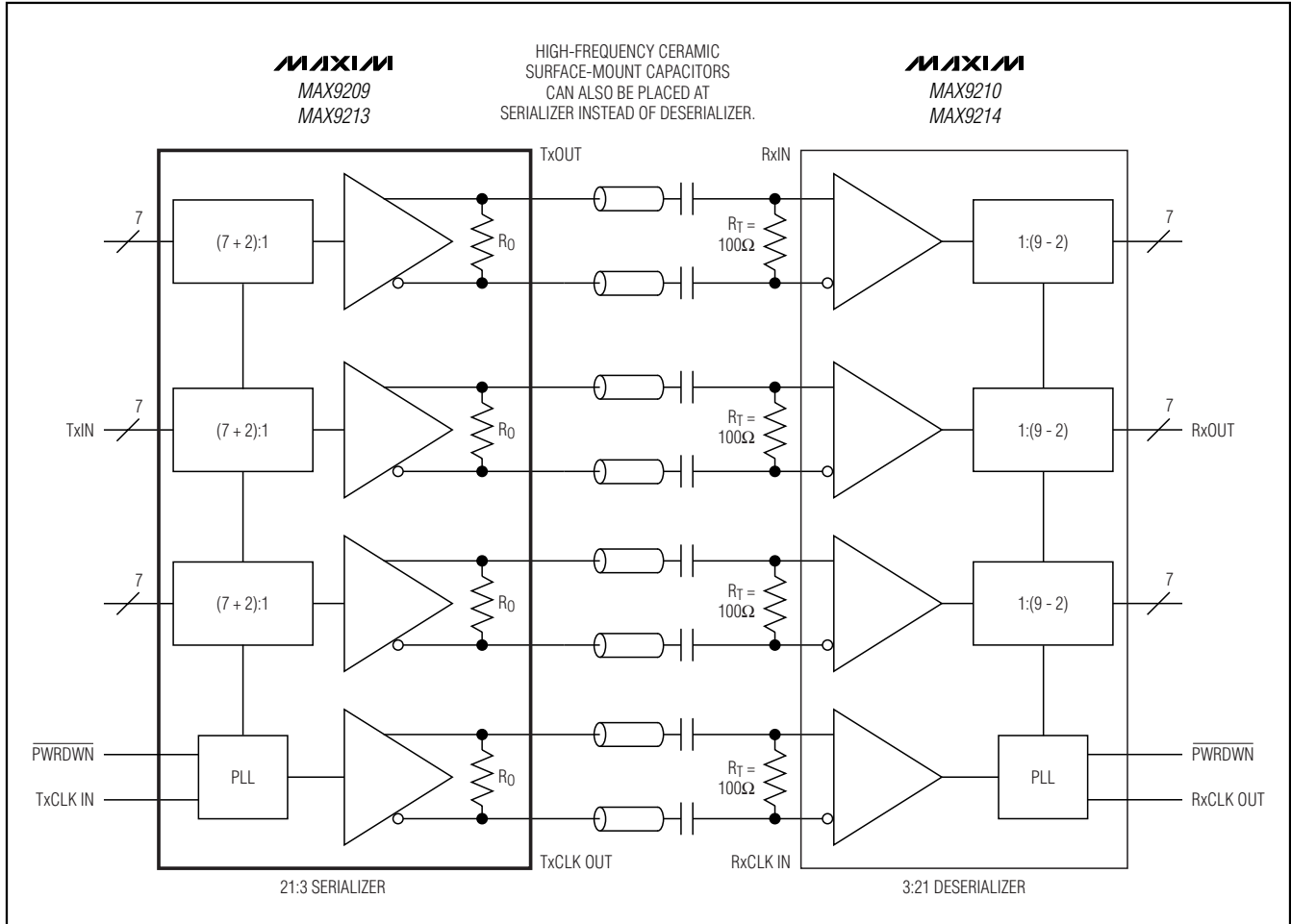

Figure 14. Two Capacitors per Link, AC-Coupled, DC-Balanced Mode

Common-mode voltage differences may be due to ground potential variation or common-mode noise. If there is more than $\pm 1V$ of difference, the receiver is not guaranteed to read the input signal correctly and may cause bit errors. AC-coupling filters low-frequency ground shifts and common-mode noise and passes high-frequency data. A common-mode voltage difference up to the voltage rating of the coupling capacitor (minus half the differential swing) is tolerated. DC-balanced coding of the data is required to maintain the differential signal amplitude and limit jitter on an AC-coupled link. A capacitor in series with each output of the LVDS driver is sufficient for AC-coupling. However,

two capacitors—one at the serializer output and one at the deserializer input—provide protection in case either end of the cable is shorted to a high voltage.

5V Tolerant Inputs

All signal and control inputs except DCB/NC are 5V tolerant and are internally pulled down to GND. The DCB/NC pin has a pullup on the MAX9209/MAX9213.

DCB/NC Pin Default Conditions

The MAX9209/MAX9213 have programmable DC balance/non-DC balance. See Table 1 for DCB/NC default settings and operating modes.

Programmable DC-Balanced 21-Bit Serializers

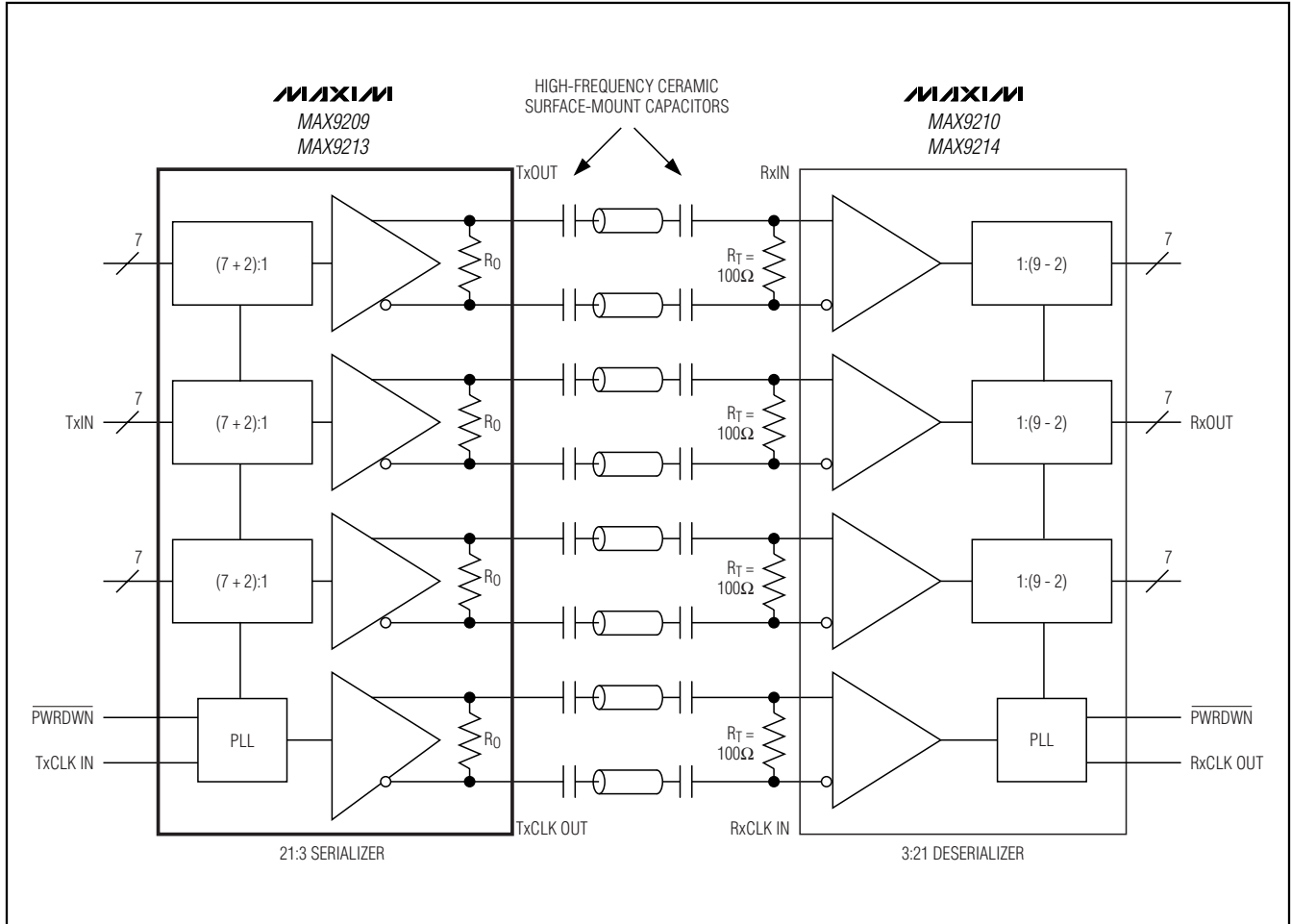

Figure 15. Four Capacitors per Link, AC-Coupled, DC-Balanced Mode

Applications Information

Selection of AC-Coupling Capacitors

Voltage droop and the DSV of transmitted symbols cause signal transitions to start from different voltage levels. Because the transition time is finite, starting the signal transition from different voltage levels causes timing jitter. The time constant for an AC-coupled link needs to be chosen to reduce droop and jitter to an acceptable level.

The RC network for an AC-coupled link consists of the LVDS receiver termination resistor (R_T), the LVDS driver output resistor (R_O), and the series AC-coupling capacitors (C). The RC time constant for two equal-value series capacitors is $(C \times (R_T + R_O)) / 2$ (Figure 14). The RC time constant for four equal-value series capacitors is $(C \times (R_T + R_O)) / 4$ (Figure 15).

R_T is required to match the transmission line impedance (usually 100Ω) and R_O is determined by the LVDS driver design, with a minimum value of 78Ω (see the *DC Electrical Characteristics* table). This leaves the capacitor selection to change the system time constant.

In the following example, the capacitor value for a droop of 2% is calculated. Jitter due to this droop is then calculated assuming a 1ns transition time:

$$C = -(2 \times t_B \times \text{DSV}) / (\ln(1 - D) \times (R_T + R_O)) \quad (\text{Eq 1})$$

where:

- C = AC-coupling capacitor (F)
- t_B = bit time (s)
- DSV = digital sum variation (integer)
- \ln = natural log
- D = droop (% of signal amplitude)
- R_T = termination resistor (Ω)

Programmable DC-Balanced 21-Bit Serializers

MAX9209/MAX9213

R_O = output resistance (Ω)

Equation 1 is for two series capacitors (Figure 14). The bit time (t_B) is the period of the parallel clock divided by 9. The DSV is 10. See equation 3 for four series capacitors (Figure 15).

The capacitor for 2% maximum droop at 8MHz parallel rate clock is:

$$C = -(2 \times t_B \times \text{DSV}) / (\ln(1 - D) \times (R_T + R_O))$$
$$C = -(2 \times 13.9\text{ns} \times 10) / (\ln(1 - .02) \times (100\Omega + 78\Omega))$$
$$C = 0.0773\mu\text{F}$$

Jitter due to droop is proportional to the droop and transition time:

$$t_J = t_T \times D \text{ (Eq 2)}$$

where:

t_J = jitter (s)

t_T = transition time (s) (0% to 100%)

D = droop (% of signal amplitude)

Jitter due to 2% droop and assumed 1ns transition time is:

$$t_J = 1\text{ns} \times 0.02$$
$$t_J = 20\text{ps}$$

The transition time in a real system depends on the frequency response of the cable driven by the serializer. The capacitor value decreases for a higher frequency parallel clock and for higher levels of droop and jitter. Use high-frequency, surface-mount ceramic capacitors.

Equation 1 altered for four series capacitors (Figure 15) is:

$$C = -(4 \times t_B \times \text{DSV}) / (\ln(1 - D) \times (R_T + R_O)) \text{ (Eq 3)}$$

Integrated Termination

The MAX9209/MAX9213 have an integrated output termination resistor across each of the four LVDS outputs. These resistors damp reflections from induced noise and mismatches between the transmission line impedance and termination resistor at the deserializer input. In DC-balanced mode, the differential output resistance is part of the RC time constant. In non-DC-balanced mode, the output termination is increased to 410Ω (typ) to reduce power. In power-down mode ($\overline{\text{PWRDWN}} = \text{low}$) or when the power supply is off, the output resistor is switched out and the LVDS outputs are high impedance.

PWRDWN and Power-Off

Driving $\overline{\text{PWRDWN}}$ low stops the PLL, switches out the integrated output termination resistors, puts the LVDS outputs in high impedance, and reduces supply current

to $50\mu\text{A}$ or less. Driving $\overline{\text{PWRDWN}}$ high starts the PLL lock to the input clock and switches in the output termination resistors. The LVDS outputs are not driven until the PLL locks. The differential output resistance pulls the outputs together and the LVDS outputs are high impedance to ground. If the power supply is turned off, the output resistors are switched out and the LVDS outputs are high impedance.

PLL Lock Time

The PLL lock time is set by an internal counter. The maximum time to lock is 32,800 clock periods. Power and clock should be stable to meet the lock-time specification. When the PLL is locking, the LVDS outputs are not active and have a differential output resistance of R_O .

Power-Supply Bypassing

There are separate power domains for LVDS, PLL, and digital circuits. Bypass each LVDS V_{CC} , PLL V_{CC} , and V_{CC} pin with high-frequency surface-mount ceramic $0.1\mu\text{F}$ and $0.001\mu\text{F}$ capacitors in parallel as close to the device as possible, with the smallest value capacitor closest to the supply pin.

LVDS Outputs

The LVDS outputs are current sources. The voltage swing is proportional to the load impedance. The outputs are rated for a differential load of $100\Omega \pm 1\%$.

Cables and Connectors

Interconnect for LVDS typically has a differential impedance of 100Ω . Use cables and connectors that have matched differential impedance to minimize impedance discontinuities.

Twisted-pair and shielded twisted-pair cables offer superior signal quality compared to ribbon cable and tend to generate less EMI due to magnetic field canceling effects. Balanced cables pick up noise as common mode, which is rejected by the LVDS receiver.

Board Layout

Keep the LVTTTL/LVCMOS input and LVDS output signals separated to prevent crosstalk. A four-layer PCB with separate layers for power, ground, LVDS outputs, and digital signals is recommended.

Programmable DC-Balanced 21-Bit Serializers

ESD Protection

The MAX9209/MAX9213 ESD tolerance is rated for IEC 61000-4-2, Human Body Model and ISO 10605 standards. IEC 61000-4-2 and ISO 10605 specify ESD tolerance for electronic systems. The IEC 61000-4-2 discharge components are $C_S = 150\text{pF}$ and $R_D = 330\Omega$ (Figure 16). For IEC 61000-4-2, the LVDS outputs are

rated for $\pm 8\text{kV}$ contact and $\pm 15\text{kV}$ air discharge. The Human Body Model discharge components are $C_S = 100\text{pF}$ and $R_D = 1.5\text{k}\Omega$ (Figure 17). For the Human Body Model, all pins are rated for $\pm 2\text{kV}$ contact discharge. The ISO 10605 discharge components are $C_S = 330\text{pF}$ and $R_D = 2\text{k}\Omega$ (Figure 18). For ISO 10605, the LVDS outputs are rated for $\pm 8\text{kV}$ contact and $\pm 25\text{kV}$ air discharge.

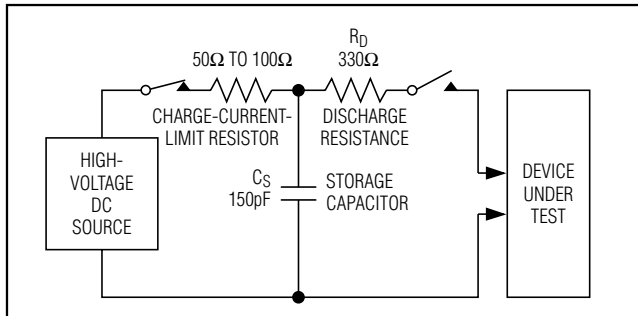

Figure 16. IEC 61000-4-2 Contact Discharge ESD Test Circuit

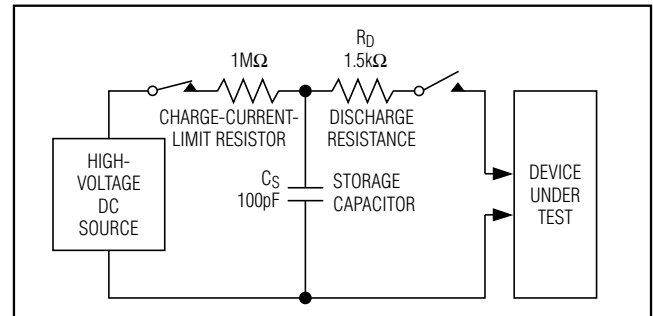

Figure 17. Human Body ESD Test Circuit

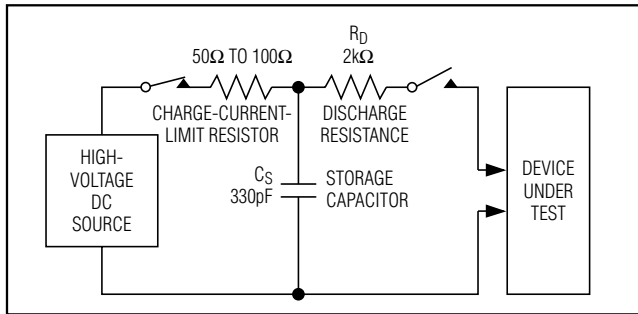
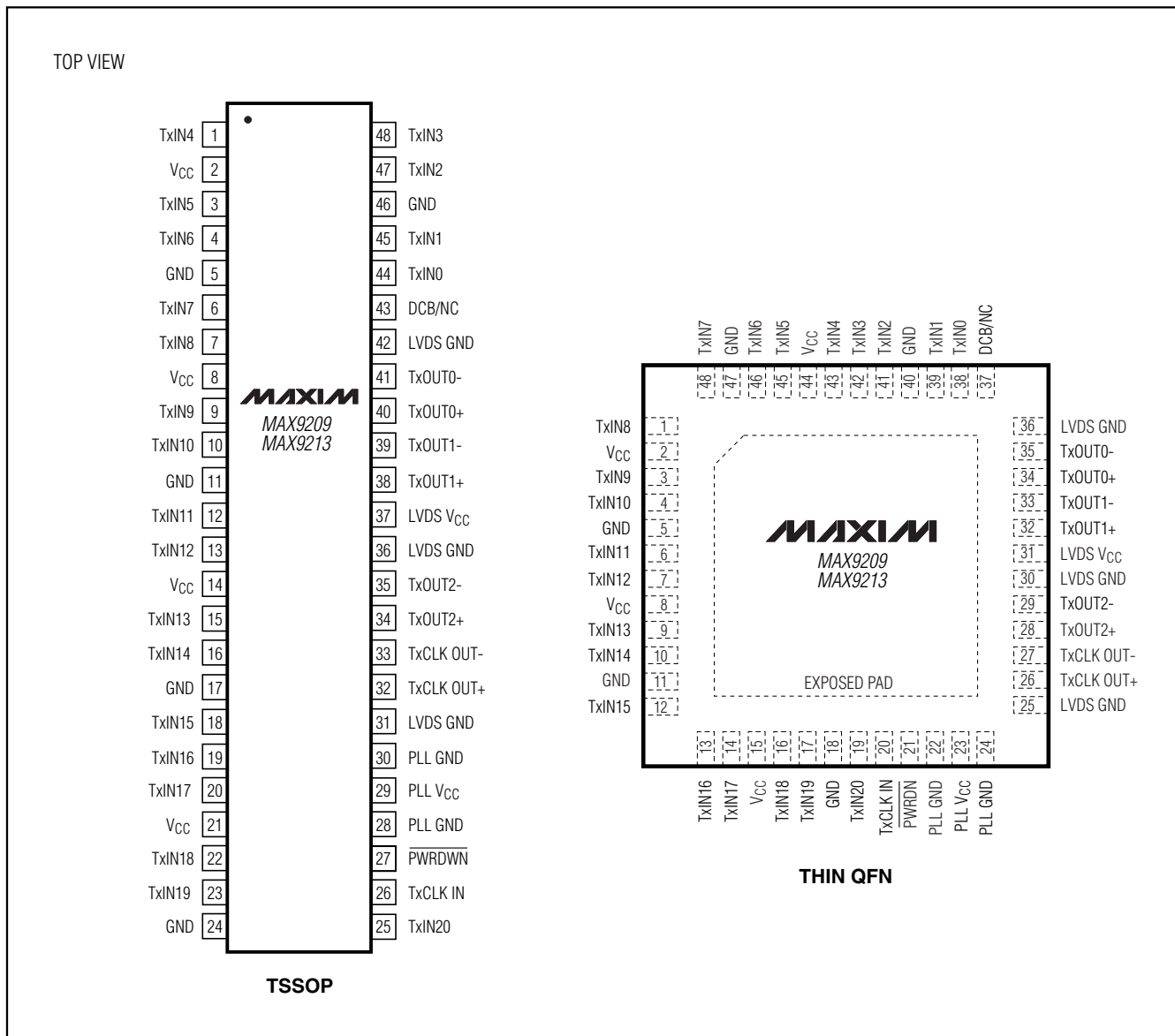

Figure 18. ISO 10605 Contact Discharge ESD Test Circuit

Programmable DC-Balanced 21-Bit Serializers

Pin Configurations

MAX9209/MAX9213



Chip Information

MAX9209 TRANSISTOR COUNT: 9458

MAX9213 TRANSISTOR COUNT: 9458

PROCESS: CMOS

Programmable DC-Balanced 21-Bit Serializers

Package Information

(The package drawing(s) in this data sheet may not reflect the most current specifications. For the latest package outline information go to www.maxim-ic.com/packages.)

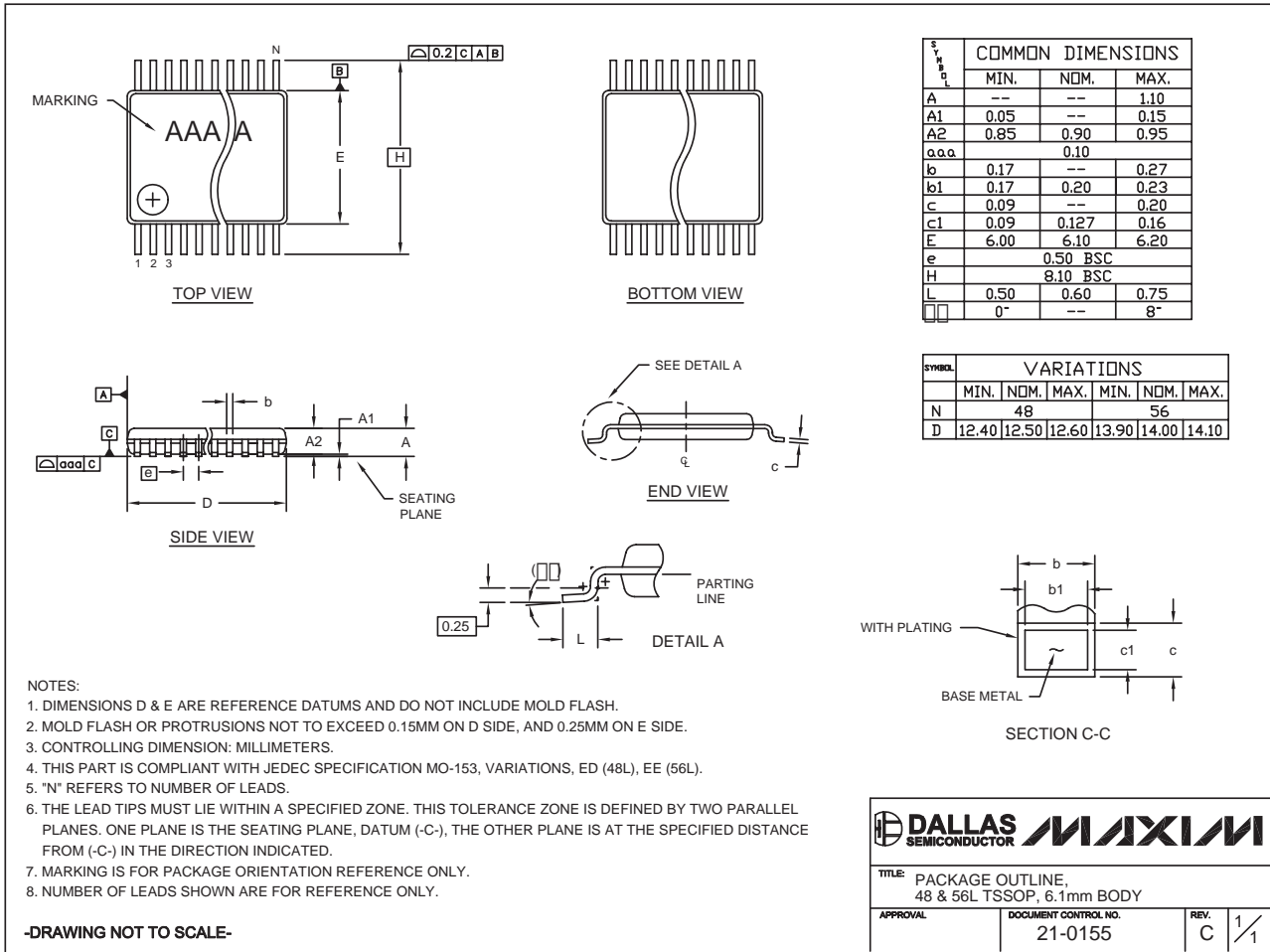

48L TSSOP-EPS

Programmable DC-Balanced 21-Bit Serializers

Package Information (continued)

(The package drawing(s) in this data sheet may not reflect the most current specifications. For the latest package outline information go to www.maxim-ic.com/packages.)

MAX9209/MAX9213

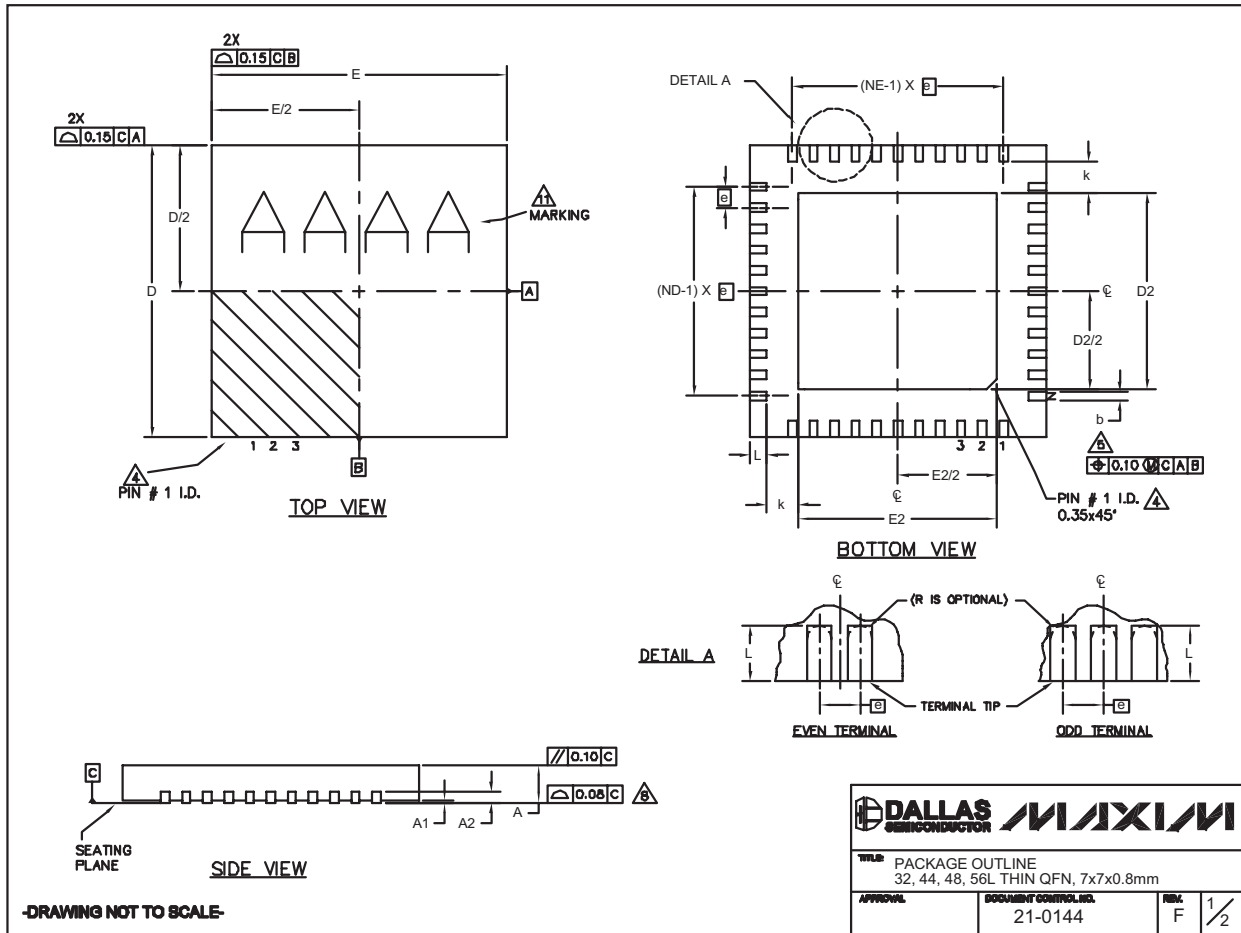

32, 44, 48L QFN.EPS

Programmable DC-Balanced 21-Bit Serializers

Package Information (continued)

(The package drawing(s) in this data sheet may not reflect the most current specifications. For the latest package outline information go to www.maxim-ic.com/packages.)

| COMMON DIMENSIONS | | | | | | | | | | | | | | EXPOSED PAD VARIATIONS | | | | | | | | | | | | | |
|-------------------|-----------|------|------|-----------|------|------|-----------|------|------|-------------------------------------|------|------|-----------|------------------------|------|---------------|----------------------|------|-----------|-------------|------|------|------|--------------------------|------|------|--------|
| PKG | 32L 7x7 | | | 44L 7x7 | | | 48L 7x7 | | | CUSTOM PKG. (T4877-1) 48L 7x7 | | | 56L 7x7 | | | PKG. CODES | DEPOPULATED LEADS | D2 | | | E2 | | | JEDEC MO220 REV. C | | | |
| | MIN. | NOM. | MAX. | MIN. | NOM. | MAX. | MIN. | NOM. | MAX. | MIN. | NOM. | MAX. | MIN. | NOM. | MAX. | | | MIN. | NOM. | MAX. | MIN. | NOM. | MAX. | | | | |
| A | 0.70 | 0.75 | 0.80 | 0.70 | 0.75 | 0.80 | 0.70 | 0.75 | 0.80 | 0.70 | 0.75 | 0.80 | 0.70 | 0.75 | 0.80 | T3277-2 | - | 4.55 | 4.70 | 4.85 | 4.85 | 4.70 | 4.85 | - | | | |
| A1 | 0 | 0.02 | 0.05 | 0 | 0.02 | 0.05 | 0 | 0.02 | 0.05 | 0 | 0.02 | 0.05 | 0 | 0.02 | 0.05 | T3277-3 | - | 4.55 | 4.70 | 4.85 | 4.85 | 4.70 | 4.85 | - | | | |
| A2 | 0.20 REF. | | | 0.20 REF. | | | 0.20 REF. | | | 0.20 REF. | | | 0.20 REF. | | | T4477-2 | - | 4.55 | 4.70 | 4.85 | 4.55 | 4.70 | 4.85 | WKGD-1 | | | |
| b | 0.25 | 0.30 | 0.35 | 0.20 | 0.25 | 0.30 | 0.20 | 0.25 | 0.30 | 0.20 | 0.25 | 0.30 | 0.20 | 0.25 | 0.30 | 0.15 | 0.20 | 0.25 | T4477-3 | - | 4.55 | 4.70 | 4.85 | 4.85 | 4.70 | 4.85 | WKGD-1 |
| D | 6.90 | 7.00 | 7.10 | 6.90 | 7.00 | 7.10 | 6.90 | 7.00 | 7.10 | 6.90 | 7.00 | 7.10 | 6.90 | 7.00 | 7.10 | 6.90 | 7.00 | 7.10 | T4877-1** | 13,24,37,48 | 4.20 | 4.30 | 4.40 | 4.20 | 4.30 | 4.40 | - |
| E | 6.90 | 7.00 | 7.10 | 6.90 | 7.00 | 7.10 | 6.90 | 7.00 | 7.10 | 6.90 | 7.00 | 7.10 | 6.90 | 7.00 | 7.10 | 6.90 | 7.00 | 7.10 | T4877-3 | - | 4.95 | 5.10 | 5.25 | 4.95 | 5.10 | 5.25 | - |
| e | 0.65 BSC. | | | 0.50 BSC. | | | 0.50 BSC. | | | 0.50 BSC. | | | 0.40 BSC. | | | T4877-4 | - | 5.40 | 5.50 | 5.60 | 5.40 | 5.50 | 5.60 | - | | | |
| k | 0.25 | - | - | 0.25 | - | - | 0.25 | - | - | 0.25 | - | - | 0.25 | - | - | 0.25 | - | - | T4877-5 | - | 2.40 | 2.50 | 2.60 | 2.40 | 2.50 | 2.60 | - |
| L | 0.45 | 0.55 | 0.65 | 0.45 | 0.55 | 0.65 | 0.30 | 0.40 | 0.50 | 0.45 | 0.55 | 0.65 | 0.30 | 0.40 | 0.50 | T4877-6 | - | 5.40 | 5.50 | 5.60 | 5.40 | 5.50 | 5.60 | - | | | |
| N | 32 | | | 44 | | | 48 | | | 44 | | | 56 | | | T4877-7 | - | 4.95 | 5.10 | 5.25 | 4.95 | 5.10 | 5.25 | - | | | |
| ND | 8 | | | 11 | | | 12 | | | 10 | | | 14 | | | T4877M-1 | - | 5.40 | 5.50 | 5.60 | 5.40 | 5.50 | 5.60 | - | | | |
| NE | 8 | | | 11 | | | 12 | | | 12 | | | 14 | | | T4877M-6 | - | 5.40 | 5.50 | 5.60 | 5.40 | 5.50 | 5.60 | - | | | |
| | | | | | | | | | | | | | | | | T4877MN-8 | - | 5.40 | 5.50 | 5.60 | 5.40 | 5.50 | 5.60 | - | | | |
| | | | | | | | | | | | | | | | | T5677-1 | - | 5.40 | 5.50 | 5.60 | 5.40 | 5.50 | 5.60 | - | | | |
| | | | | | | | | | | | | | | | | T5677-2 | - | 5.40 | 5.50 | 5.60 | 5.40 | 5.50 | 5.60 | - | | | |

** NOTE: T4877-1 IS A CUSTOM 48L PKG. WITH 4 LEADS DEPOPULATED. TOTAL NUMBER OF LEADS ARE 44.

NOTES:

- DIMENSIONING & TOLERANCING CONFORM TO ASME Y14.5M-1994.
- ALL DIMENSIONS ARE IN MILLIMETERS. ANGLES ARE IN DEGREES.
- N IS THE TOTAL NUMBER OF TERMINALS.
- THE TERMINAL #1 IDENTIFIER AND TERMINAL NUMBERING CONVENTION SHALL CONFORM TO JEDEC 95-1 SPP-012. DETAILS OF TERMINAL #1 IDENTIFIER ARE OPTIONAL, BUT MUST BE LOCATED WITHIN THE ZONE INDICATED. THE TERMINAL #1 IDENTIFIER MAY BE EITHER A MOLD OR MARKED FEATURE.
- DIMENSION b APPLIES TO METALLIZED TERMINAL AND IS MEASURED BETWEEN 0.25 mm AND 0.30 mm FROM TERMINAL TIP.
- ND AND NE REFER TO THE NUMBER OF TERMINALS ON EACH D AND E SIDE RESPECTIVELY.
- DEPOPULATION IS POSSIBLE IN A SYMMETRICAL FASHION.
- COPLANARITY APPLIES TO THE EXPOSED HEAT SINK SLUG AS WELL AS THE TERMINALS.
- DRAWING CONFORMS TO JEDEC MO220 EXCEPT THE EXPOSED PAD DIMENSIONS OF T4877-1/-3/-4/-5/-6 & T5677-1.
- WARPAGE SHALL NOT EXCEED 0.10 mm.
- MARKING IS FOR PACKAGE ORIENTATION REFERENCE ONLY
- NUMBER OF LEADS SHOWN ARE FOR REFERENCE ONLY

-DRAWING NOT TO SCALE-

| | | | |
|--|---|-------------------|------------|
| | | | |
| TITLE: PACKAGE OUTLINE 32, 44, 48, 56L THIN QFN, 7x7x0.8mm | | | |
| APPROVAL: | DOCUMENT CONTROL NO.: 21-0144 | REV.: F | 2/2 |

Programmable DC-Balanced 21-Bit Serializers

MAX9209/MAX9213

| REVISION NUMBER | REVISION DATE | DESCRIPTION | PAGES CHANGED |
|-----------------|---------------|--|----------------------------|
| 3 | 6/07 | — | 1–5, 9, 14, 15, 18, 19, 20 |
| 4 | 10/07 | Removed all references to MAX9211 and MAX9215. | 1–20 |

Maxim cannot assume responsibility for use of any circuitry other than circuitry entirely embodied in a Maxim product. No circuit patent licenses are implied. Maxim reserves the right to change the circuitry and specifications without notice at any time.

Maxim Integrated Products, 120 San Gabriel Drive, Sunnyvale, CA 94086 408-737-7600 _____ 21